

Situatie

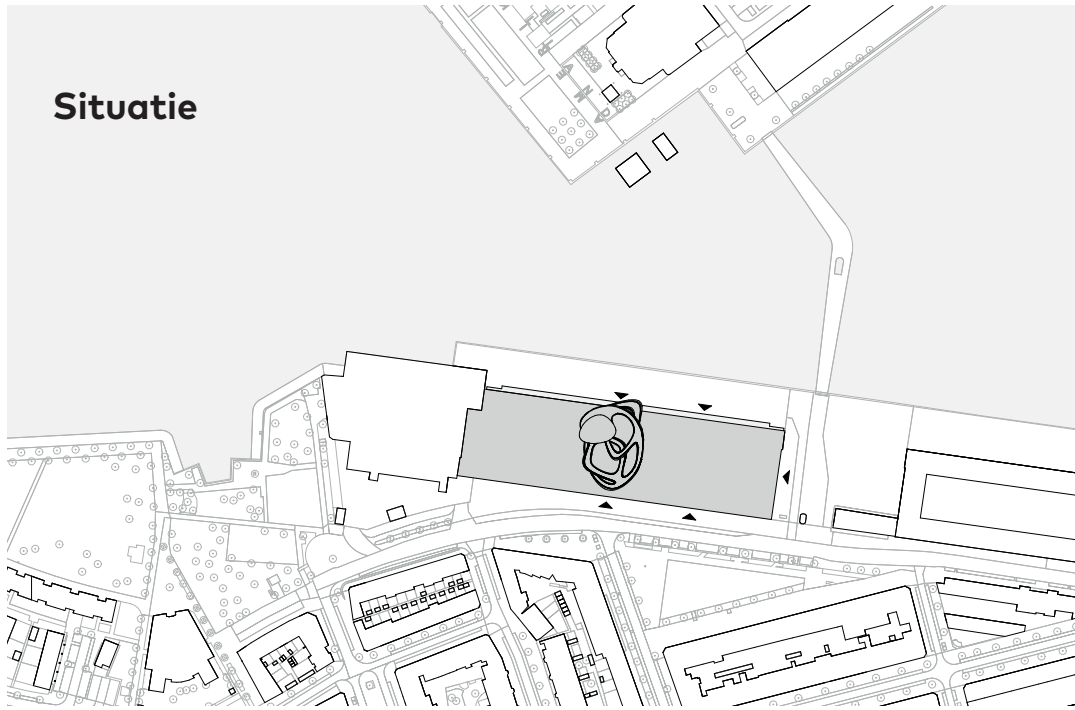

Plattegronden

1^e verdieping

1. Tornado trap
2. Lobby
3. Lift
4. Espresso bar
5. Balkon
6. Atrium
7. Museumgalerie
8. Opslag museum
9. Kantoren
10. Techniek

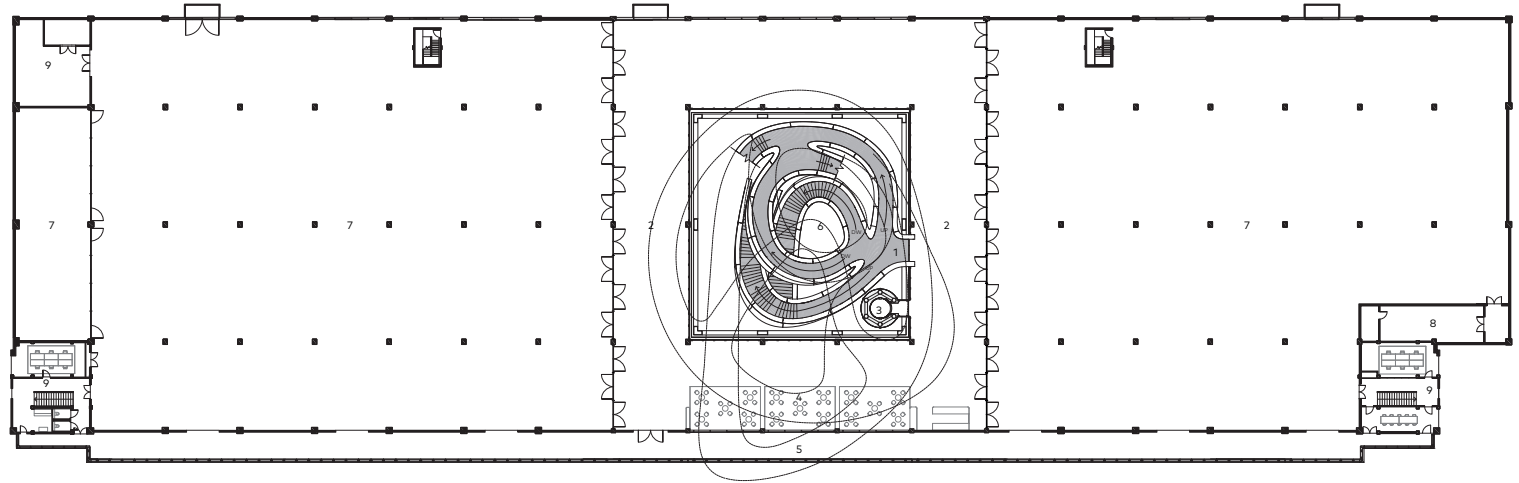

Begane grond

1. Entree
2. Informatiebalie
3. Tornado trap, fast en slow lane
4. Garderobe
5. Café
6. Lift
7. Museumwinkel
8. Ontmoetingspunt
9. Toilet
10. Museumgalerie
11. Plein
12. Keuken
13. Bakkerij
14. Keuken Plein
15. Kantoren
16. Personeelsrestaurant
17. Techniek
18. Rivier 'Maas'

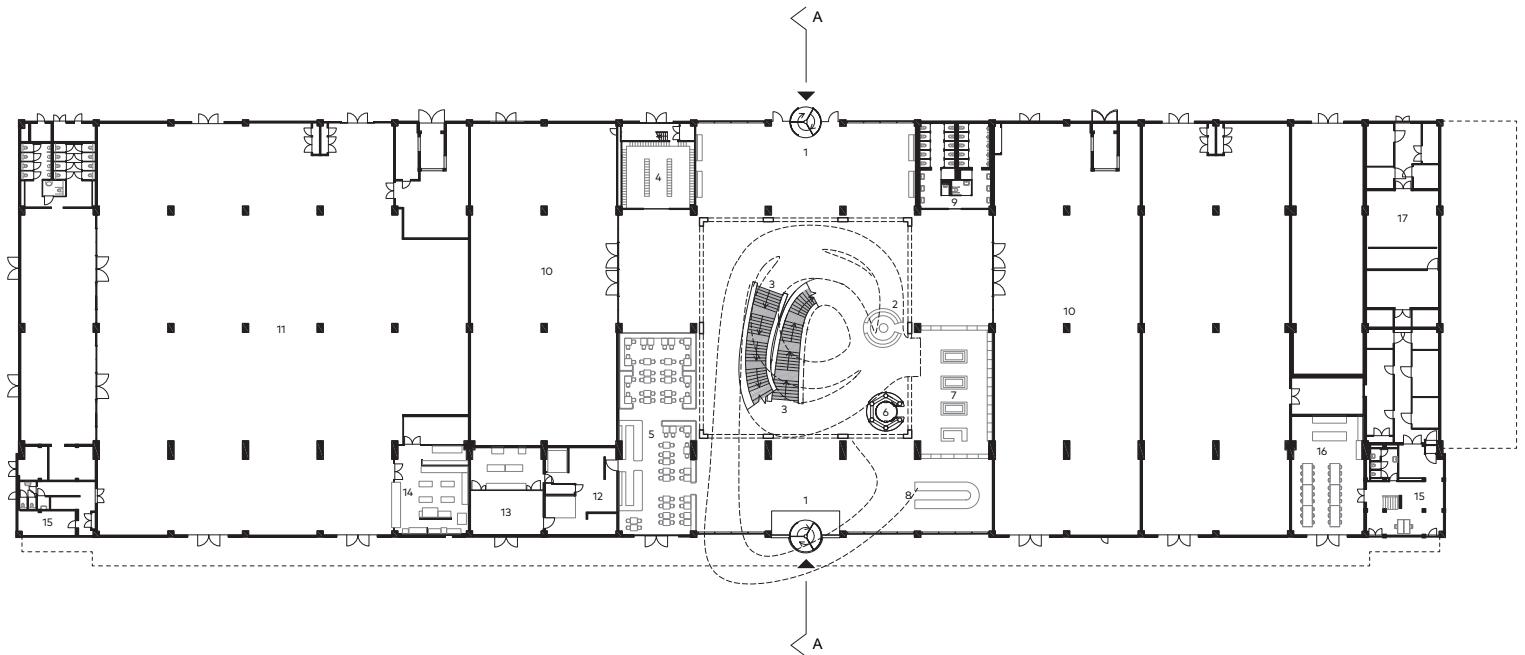

0 7,5 15 m

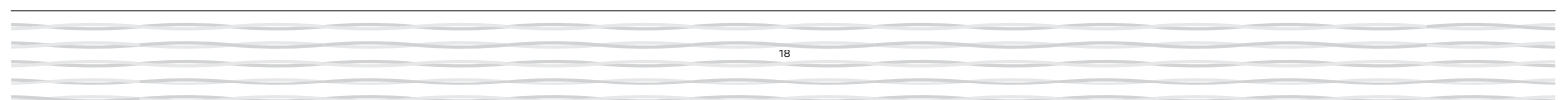



Trap detail

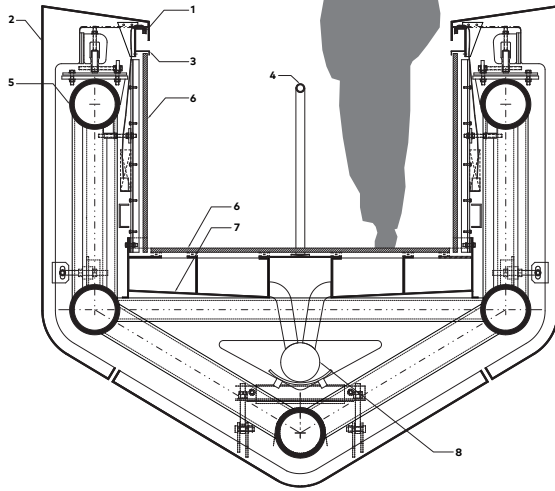

1. LED-lijnverlichting
2. 6 mm roestvast staal
3. Verlichtingskoof
4. Leuning
5. Stalen spaceframe
6. Houten bekleding
7. Drainagegoot
8. Drainagebuis



Doorsnede A-A

1. Entree Veerlaan
2. Entree Paul Nijghkade
3. Atrium
4. Lobby
5. Espresso bar
6. Slow lane cockpit

